



POLYTROPIC

• POOL HEATING SOLUTIONS •



INDOOR Inverter

Make your pool heating disappear!



INDOOR XM Mono
and XM Tri

INDOOR S and M



Video demo

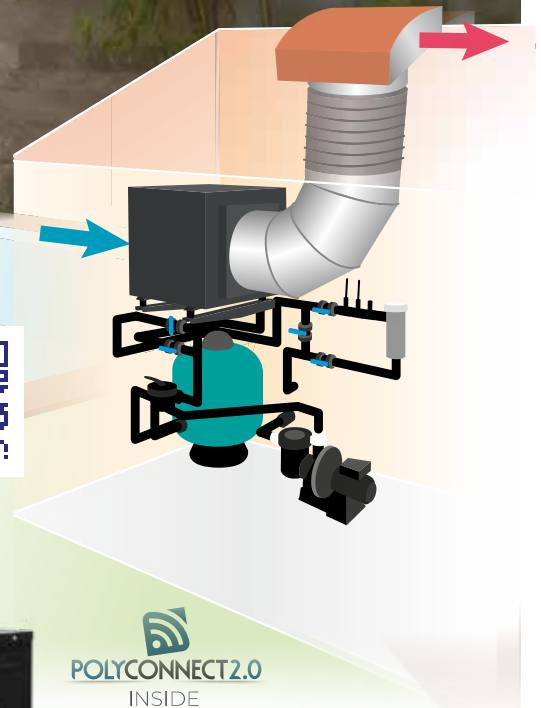

POLYCONNECT 2.0
INSIDE



4G
optional



DISCRETION AND AESTHETICS FOR THIS HEAT PUMP, WHICH IS INSTALLED INSIDE THE POOLHOUSE TO MAKE ITSELF INVISIBLE.

A POLYTROPIC exclusive. The machine is in your pool house, which acts as a sound insulator! Almost invisible from the outside, this exclusive swimming pool heat pump disappears from the landscape. No need to hide it anymore!



Technical specifications

MODEL	Indoor S FI	Indoor M FI	Indoor XM FI 1-phase	Indoor XM FI 3-phase
SCOP acc. to EN 17645	7,3	7,2	7,2	7,2
Classification acc. to EN 17645	A	A	A	A
Recommended pool size*	45-55 m ³	55-85 m ³	85-105 m ³	85-105 m ³
Air 26°C / Water 26°C / Humidity 80%				
Energy Output BOOST Mode	10,3 kW	15,9 kW	19,8 kW	19,8 kW
BOOST Mode COP	6,4	6,3	6,2	6,2
Energy Output SMART Mode	10,3 ~ 3,7 kW	15,9 ~ 5,6 kW	19,8 ~ 6,4 kW	19,8 ~ 6,4 kW
SMART Mode COP	6,4 ~ 11,6	6,3 ~ 11,5	6,2 ~ 11,0	6,2 ~ 11,0
Energy Output ECO-Silence Mode	3,7 kW	5,6 kW	6,4 kW	6,4 kW
ECO-Silence Mode COP	11,6	11,5	11,0	11,0
Air 15°C / Water 26°C / Humidity 70%HR**				
Energy Output BOOST Mode	7,2 kW	10,6 kW	14,9 kW	14,9 kW
BOOST Mode COP	4,7	4,6	4,6	4,6
Energy Output SMART Mode	7,2 ~ 3,4 kW	10,6 ~ 3,8 kW	14,9 ~ 5,1 kW	14,9 ~ 5,1 kW
SMART Mode COP	4,7 ~ 7,0	4,6 ~ 6,9	4,6 ~ 6,8	4,6 ~ 6,8
Energy Output ECO-Silence Mode	3,4 kW	3,8 kW	5,1 kW	5,1 kW
ECO-Silence Mode COP	7,0	6,9	6,8	6,8
Air 7°C / Water 26°C / Humidity 90%				
Energy Output BOOST Mode	5,4 kW	8,0 kW	11,2 kW	11,2 kW
BOOST Mode COP	3,7	3,6	3,6	3,6
Air -7°C / Water 26°C / Humidity 0%				
Energy Output BOOST Mode	3,5 kW	5,2 kW	7,3 kW	7,3 kW
BOOST Mode COP	2,8	2,7	2,7	2,7
Maximum noise level (at 10m) according to EN ISO 3744 : 2010	33 dB(A)	30 dB(A)	32 dB(A)	32 dB(A)
Temperature working range	-15°C -> 43°C			
Installation				
Hydraulic connections	1,5" / 50 mm			
Power	230 V / 1~+N / 50 Hz			400V / 3~+N / 50 Hz
Circuit breaker and cable size (for 20m)	C 10 A (3G 2,5 mm ²)	C 16 A (3G 2,5 mm ²)	C 20 A (3G 2,5 mm ²)	3* C 10 A (5G 2,5 mm ²)
Power Input Max (air 26°C)	1,7 kW	2,7 kW	3,3 kW	3,3 kW
Minimal water flow	3 m ³ /h	5 m ³ /h	6 m ³ /h	6 m ³ /h
Dimensions in mm (L x l x h)	726 x 770 x 637		886 x 780 x 1276	
Weight (net)	62 kg (75 kg)	69 kg (82 kg)	131 kg (154 kg)	131 kg (154 kg)

* May to September with cover.

** Tests run with air temperature of 15°C, water inlet temperature of 26°C and water outlet temperature of 28°C in order to define the required water flow, heating capacity and consumption. In accordance with FPP recommendations (French Pool Federation).

Features and **benefits**



SIMPLE AND INTUITIVE OPERATION

An intelligent electronic controller, tailor-made to :

- Program and display the temperature,
- Set time windows,
- With 3 operating modes: **Heating, Cooling and Automatic.**



OPTIMAL PERFORMANCES

Optimal Twist : a spiral wound PVC/titanium condenser that is impervious to corrosion.



2D Technology : an INVERTER compressor with enhanced performance, very high COP thanks to its speed variation hertz by hertz.



DC Brushless : a fan with variable speed down to the rpm to ensure optimum performance.



COP IMPROVED

An efficient electronic expansion valve, which adapts the flow of refrigerant gas according to climatic conditions.



INTELLIGENT OPERATING MODE

PolySmart Control : The heat pump regulates its own power to adapt to the needs of your pool, depending on the water temperature and the ambient temperature.



EXCLUSIVE «LOW TEMPERATURE» SYSTEM

- Defrosting by cycle inversion,
- Compressor crankcase preheating,
- Condensate anti-freeze system,
- Automatic control of the «low temperature» system.



CONNECTED SOLUTION

PolyConnect inside : wifi module included for remote control via smartphone and permanent supervision by the Technician.

ACCESSORIES INCLUDED: 50 mm hydraulic connection kit, 4 «Silent block» anti-vibration pads, condensate drain kit.



PolySmart Control : major assets

EXCLUSIVE REGULATION AND SAVINGS

- **Optimise the power required to maintain the temperature** of your pool, by cross-referencing ambient temperature and water temperature data.
- **Anticipation of the pool's energy requirements** thanks to advanced dual input regulation.
- **Much higher COP** on average over the season + **low noise level.**
- Inverter compressor with «oversized» heat exchangers = **higher COP.**
- Brushless fan (variable speed) = **lower noise level.**
- Combination of Inverter compressor and Brushless fan = **power regulated** according to pool requirements.

3 OPERATING MODES



Mode BOOST

We ask the machine for maximum power to heat up quickly.



Mode SMART

The power and sound level are automatically adjusted according to the temperature outside and in your pool.

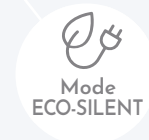

Mode ECO-SILENT

The maximum power delivered by the machine is limited to ensure the lowest noise level and the highest COP at all times.

HIGHER COP



LOWER electricity bill



LOWER noise levels



BETTER user comfort

Installation accessories



INDOOR S AND INDOOR M INSTALLATION « ROOF-TOP »

Front Wall Suction / Vertical discharge and Roof-Top discharge
Code : **A00400004** (Roof-top discharge 'Tile' colour)

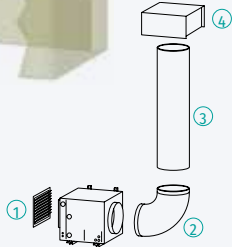

- Kit contents :
1. Galvanised steel grille 600 x 400*
 2. Galvanised steel elbow 90° Ø450
 3. Flexible duct Ø450, 2 ml (with 2 fixing collars)
 4. Roof outlet Ø450, «tile» colour (with sealing bib)

INDOOR XM INSTALLATION « ROOF-TOP »

Front Wall Suction / Vertical discharge and Roof-Top discharge
Code : **A00400001** (Roof-top discharge 'Tile' colour)

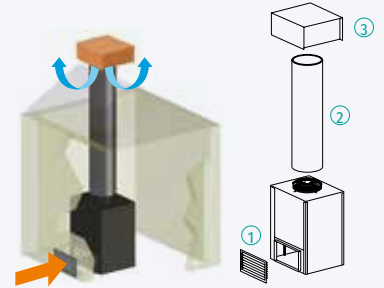

- Kit contents :
1. Galvanised steel grille 600 x 300*
 2. Flexible duct Ø450, 2 ml (with 2 fixing collars)
 3. Roof outlet Ø450 «tile» colour (with sealing bib)

INDOOR XM INSTALLATION « SIDE-WALL OR THROUGH THE ROOM »

Front inlet / Side/rear outlet
Code : **A00400003** (front exit)

- Kit contents :
1. Galvanised steel grille 600 x 300*
 2. 90° galvanised steel elbow Ø450
 3. Flexible duct Ø450, 2 ml (with 2 fixing collars)
 4. Round plenum Ø450/square 600 x 600
 5. Galvanised steel grille 600 x 600*

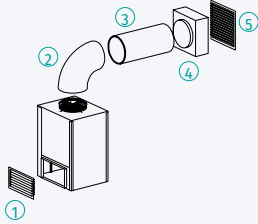
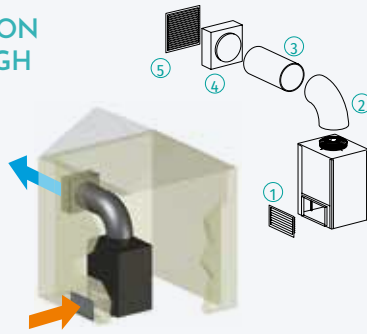

600 X 600 ANTI-NOISE ACOUSTIC GRILL

Code : **A00400035**

INDOOR S AND INDOOR M INSTALLATION « SIDEWALL OR THROUGH THE ROOM »

Front inlet / Side/rear outlet
Code : **A00400007** (front exit)

- Kit contents :
1. Galvanised steel grille 600 x 400*
 2. Flexible duct Ø450, 2 ml (with 2 fixing collars)
 3. Round plenum Ø450/square 600 x 600
 4. Galvanised steel grille 600 x 600*

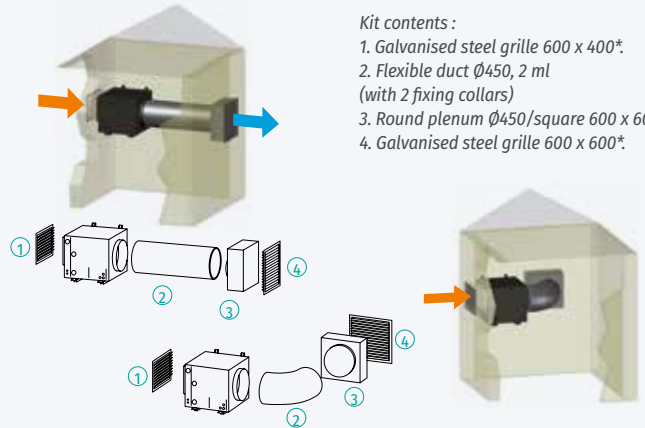

* Optional «choice of RAL colour» for the grid to match the pool environment: study on request.



POLYCONNECT₂₀



CONNECTED SOLUTION

Easily connect the heat pump by scanning the QR code, check the status via the free app and benefit from secure remote supervision for preventive maintenance and remote diagnosis by Polytropic technicians.

